

**TURBOSWITCH™ "A". ULTRA-FAST HIGH VOLTAGE DIODE**
**MAIN PRODUCTS CHARACTERISTICS**

$I_{F(AV)}$	<b>8A</b>
$V_{RRM}$	<b>600V</b>
$t_{rr}$ (typ)	<b>25ns</b>
$V_F$ (max)	<b>1.5V</b>

**FEATURES AND BENEFITS**

- SPECIFIC TO "FREEWHEEL MODE" OPERATIONS: Freewheel or Booster Diode.
- ULTRA-FAST RECOVERY.
- VERY LOW OVERALL POWER LOSSES IN BOTH THE DIODE AND THE COMPANION TRANSISTOR.
- HIGH FREQUENCY OPERATIONS.
- CECC APPROVED.

**DESCRIPTION**

The TURBOSWITCH is a very high performance series of ultra-fast high voltage power diodes from 600V to 1200V.

TURBOSWITCH, A family, drastically cuts losses in both the diode and the associated switching IGBT or MOSFET in all "Freewheel Mode" operations and is particularly suitable and efficient

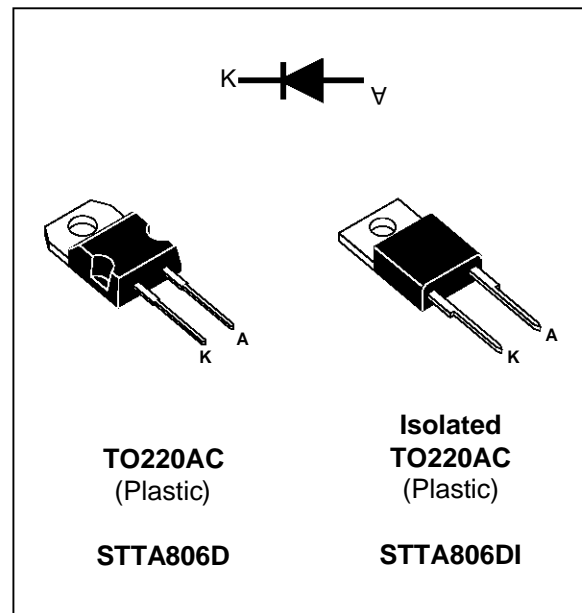

in Motor Control Freewheel applications and in Booster diode applications in Power Factor Control circuitries.

Packaged in TO220AC and in isolated TO220AC, these 600V devices are particularly intended for use on 240V domestic mains.

**ABSOLUTE MAXIMUM RATINGS**

Symbol	Parameter	Value	Unit
$V_{RRM}$	Repetitive peak reverse voltage	600	V
$V_{RSM}$	Non repetitive peak reverse voltage	600	V
$I_{F(RMS)}$	RMS forward current	20	A
$I_{FRM}$	Repetitive peak forward current ( $t_p = 5 \mu s$ , $f = 5 kHz$ )	120	A
$T_j$	Max operating junction temperature	-65 to 150	°C
$T_{stg}$	Storage temperature	-65 to 150	°C

TM : TURBOSWITCH is a trademark of SGS-THOMSON MICROELECTRONICS.

## STTA806D(I)

### THERMAL AND POWER DATA

Symbol	Parameter	Conditions	Value	Unit
$R_{th(j-c)}$	Junction to case thermal resistance	STTA806D STTA806DI	2.2 3.3	$^{\circ}\text{C}/\text{W}$
$P_1$	Conduction power dissipation (see fig. 2)	$I_{F(AV)} = 8\text{A}$ $\delta = 0.5$ STTA806D $T_C = 118^{\circ}\text{C}$ STTA806DI $T_C = 102^{\circ}\text{C}$	14.5	W
$P_{max}$	Total power dissipation $P_{max} = P_1 + P_3$ ( $P_3 = 10\% P_1$ )	STTA806D $T_C = 115^{\circ}\text{C}$ STTA806DI $T_C = 97^{\circ}\text{C}$	16	W

### STATIC ELECTRICAL CHARACTERISTICS (see Fig.2)

Symbol	Parameter	Test Conditions		Min	Typ	Max	Unit
$V_F$ *	Forward voltage drop	$I_F = 8\text{A}$	$T_j = 25^{\circ}\text{C}$ $T_j = 125^{\circ}\text{C}$			1.75 1.5	V V
$I_R$ **	Reverse leakage current	$V_R = 0.8$ $\times V_{RRM}$	$T_j = 25^{\circ}\text{C}$ $T_j = 125^{\circ}\text{C}$			100 4	$\mu\text{A}$ mA

Test pulses widths : \*  $t_p = 380 \mu\text{s}$ , duty cycle < 2%

\*\*  $t_p = 5 \text{ms}$ , duty cycle < 2%

### DYNAMIC ELECTRICAL CHARACTERISTICS

#### TURN-OFF SWITCHING (see Fig.3)

Symbol	Parameter	Test Conditions	Min	Typ	Max	Unit
$t_{rr}$	Reverse recovery time	$T_j = 25^{\circ}\text{C}$ $I_F = 0.5 \text{A}$ $I_R = 1\text{A}$ $I_{rr} = 0.25\text{A}$ $I_F = 1 \text{A}$ $di_F/dt = -50\text{A}/\mu\text{s}$ $V_R = 30\text{V}$		25	52	ns
$I_{RM}$	Maximum reverse recovery current	$T_j = 125^{\circ}\text{C}$ $V_R = 400\text{V}$ $I_F = 8\text{A}$ $di_F/dt = -64 \text{A}/\mu\text{s}$ $di_F/dt = -500 \text{A}/\mu\text{s}$		14	5.5	A
S factor	Softness factor	$T_j = 125^{\circ}\text{C}$ $V_R = 400\text{V}$ $I_F = 8\text{A}$ $di_F/dt = -500 \text{A}/\mu\text{s}$		0.47		/

#### TURN-ON SWITCHING (see Fig.4)

Symbol	Parameter	Test Conditions	Min	Typ	Max	Unit
$t_{fr}$	Forward recovery time	$T_j = 25^{\circ}\text{C}$ $I_F = 8 \text{A}$ , $di_F/dt = 64 \text{A}/\mu\text{s}$ measured at, $1.1 \times V_{Fmax}$			500	ns
$V_{Fp}$	Peak forward voltage	$T_j = 25^{\circ}\text{C}$ $I_F = 8\text{A}$ , $di_F/dt = 64 \text{A}/\mu\text{s}$			10	V

## APPLICATION DATA

The TURBOSWITCH "A" is especially designed to provide the lowest overall power losses in any "FREEWHEEL Mode" application (Fig.1) considering both the diode and the companion

transistor, thus optimizing the overall performance in the end application.

The way of calculating the power losses is given below:

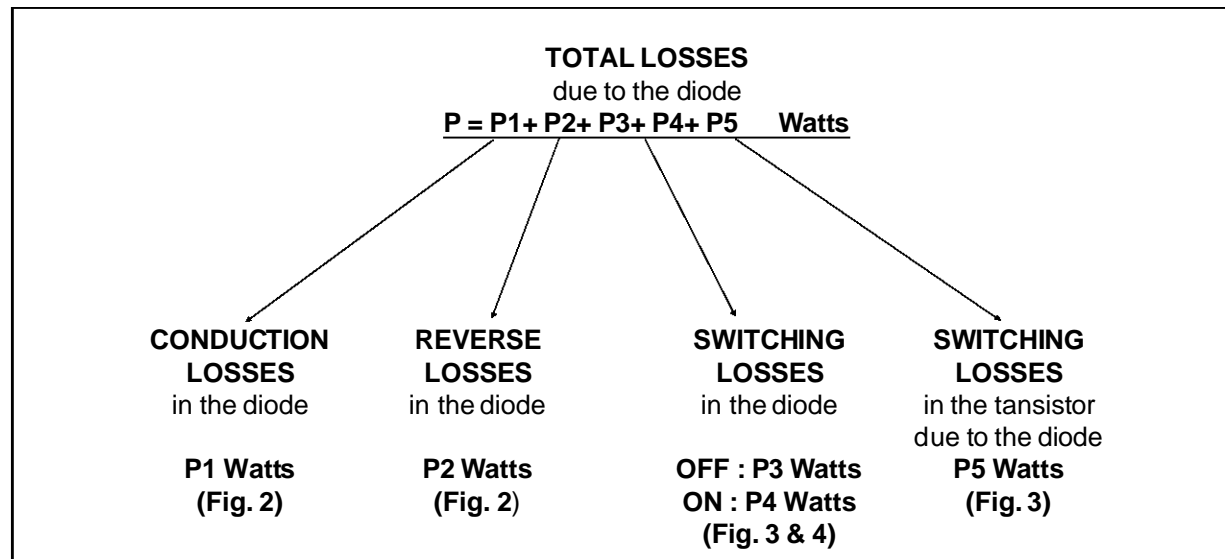
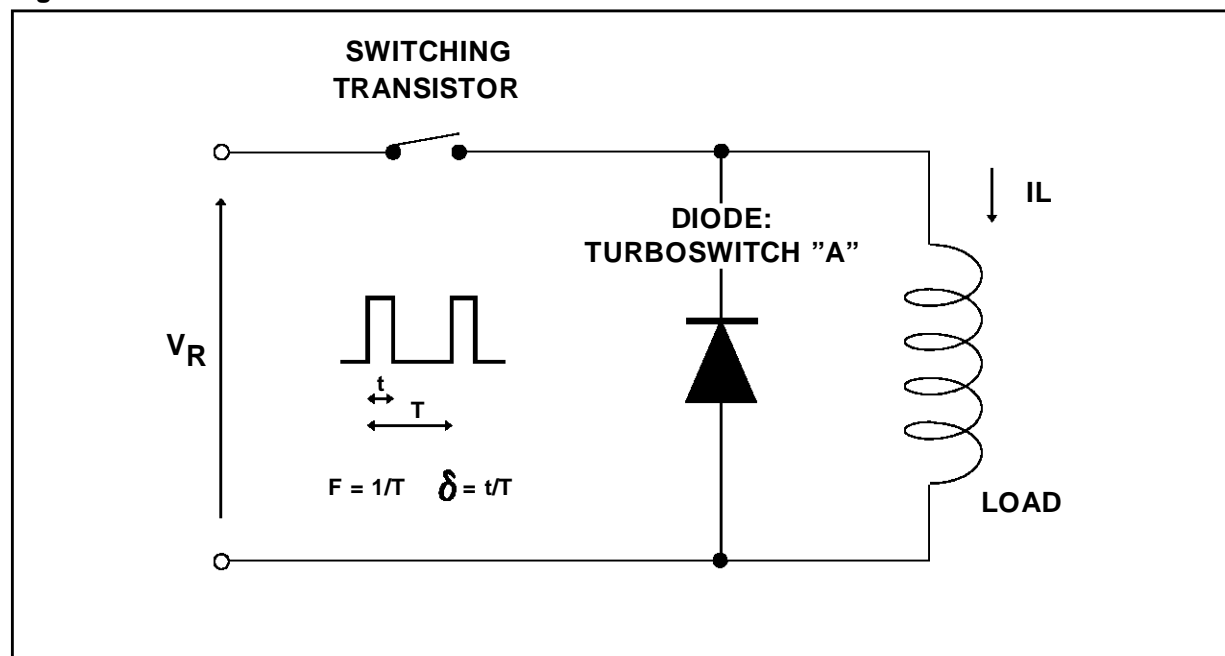
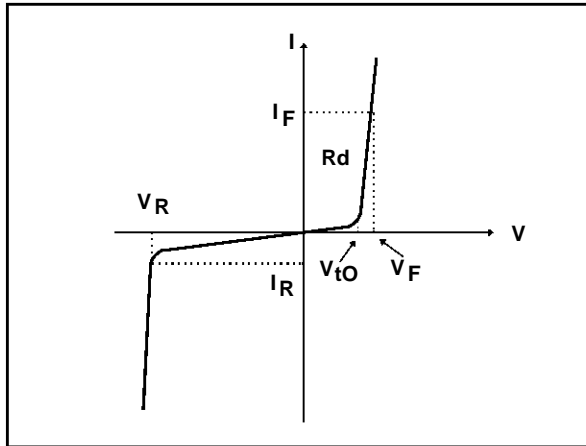

Fig. 1 : "FREEWHEEL" MODE.



APPLICATION DATA (Cont'd)

Fig. 2: STATIC CHARACTERISTICS



Conduction losses :

$$P1 = V_{t0} \cdot I_F(AV) + R_d \cdot I_F^2(RMS)$$

with

$$V_{t0} = 1.15 \text{ V}$$

$$R_d = 0.043 \text{ Ohm}$$

(Max values at 125°C)

Reverse losses :

$$P2 = V_R \cdot I_R \cdot (1 - \delta)$$

Fig. 3: TURN-OFF CHARACTERISTICS

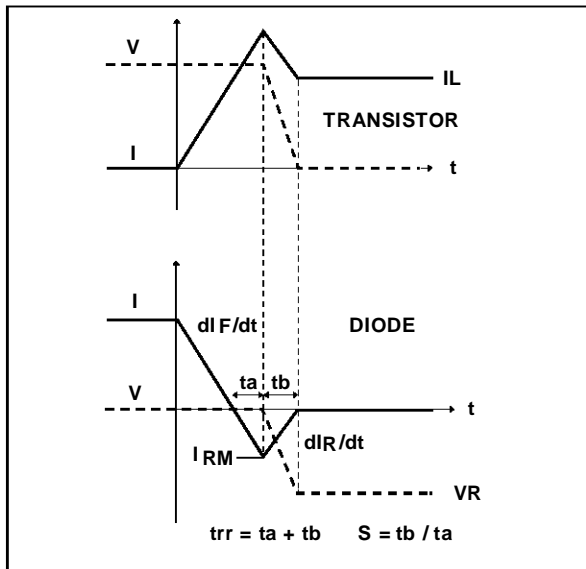

Turn-on losses :

(in the transistor, due to the diode)

$$P5 = \frac{V_R \times I_{RM}^2 \times (3 + 2 \times S) \times F}{6 \times dl_F/dt} + \frac{V_R \times I_{RM} \times I_L \times (S + 2) \times F}{2 \times dl_F/dt}$$

Turn-off losses (in the diode) :

$$P3 = \frac{V_R \times I_{RM}^2 \times S \times F}{6 \times dl_F/dt}$$

P3 and P5 are suitable for power MOSFET and IGBT

Fig. 4: TURN-ON CHARACTERISTICS

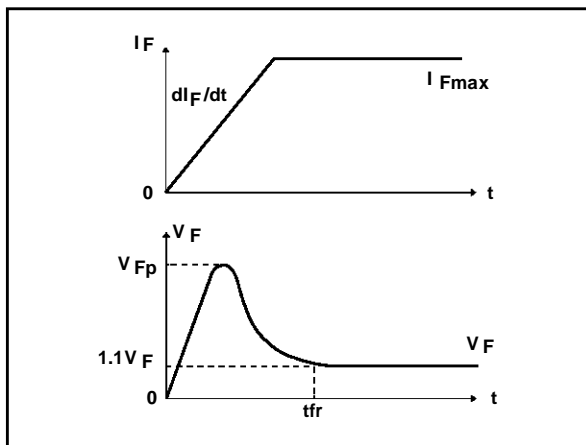

Turn-on losses :

$$P4 = 0.4 (V_{FP} - V_F) \cdot I_{Fmax} \cdot t_{rr} \cdot F$$

Fig 5 : Conduction losses versus average current

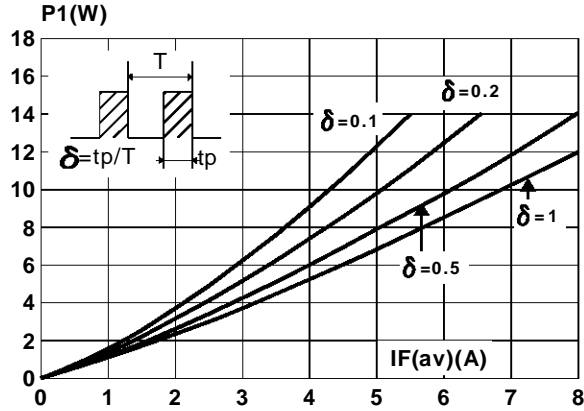

Fig 6 : Switching OFF losses versus  $dIF/dt$

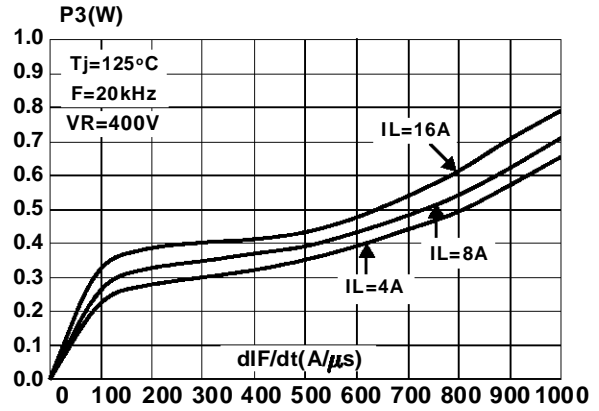

Fig 7 : Switching ON losses versus  $dIF/dt$

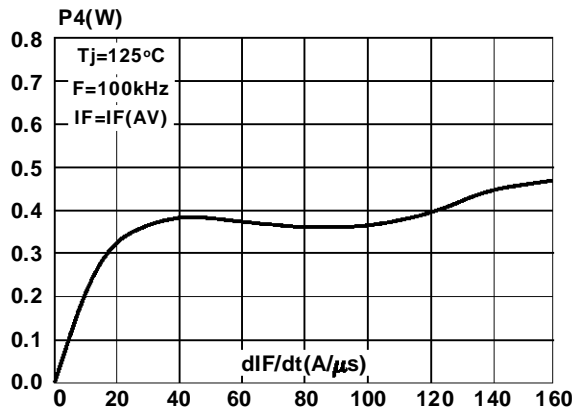

Fig 8 : Switching losses in transistor due to the diode

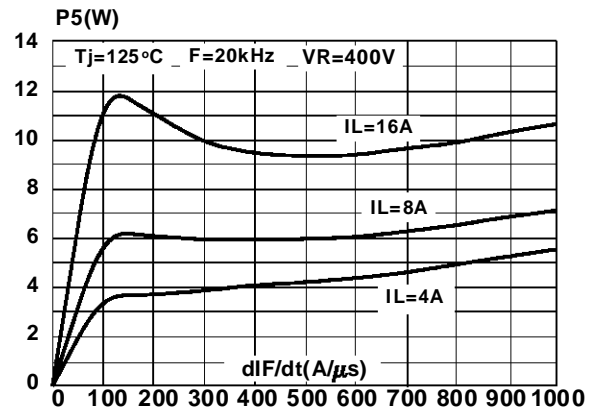

Fig 9 : Forward voltage drop versus forward current

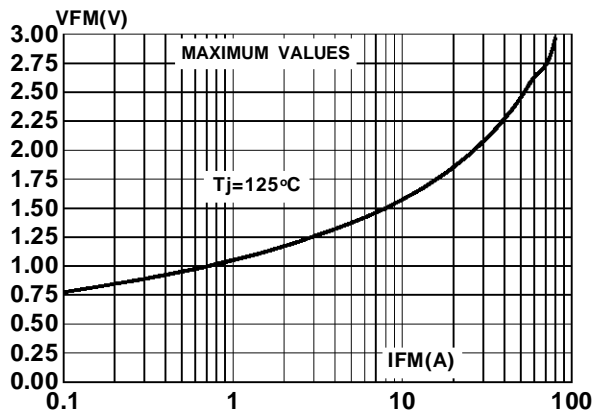

Fig 10 : Relative variation of thermal transient impedance junction to case versus pulse duration

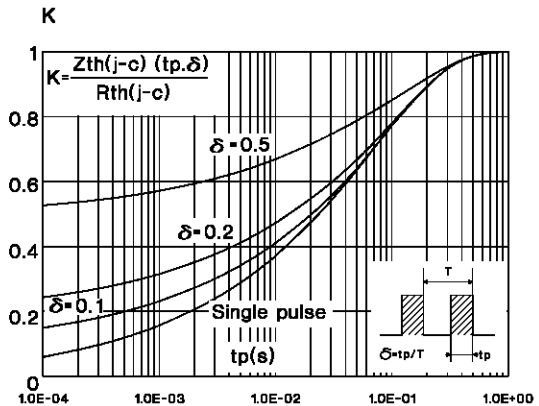

Fig 11 : Peak reverse recovery current versus  $dI_F/dt$

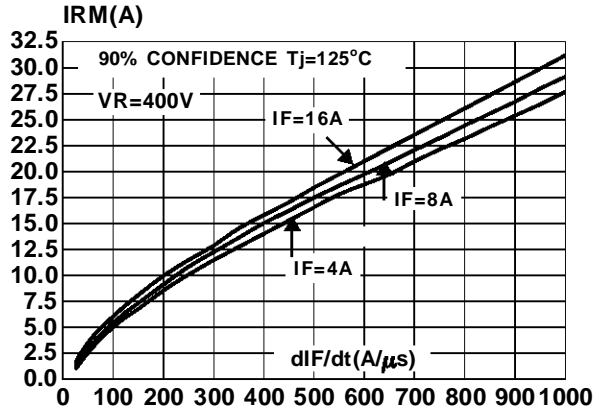

Fig 12 : Reverse recovery time versus  $dI_F/dt$

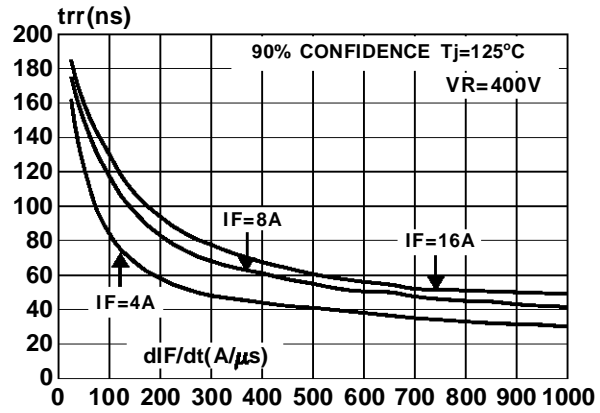

Fig 13 : Softness factor (tb/ta) versus  $dI_F/dt$

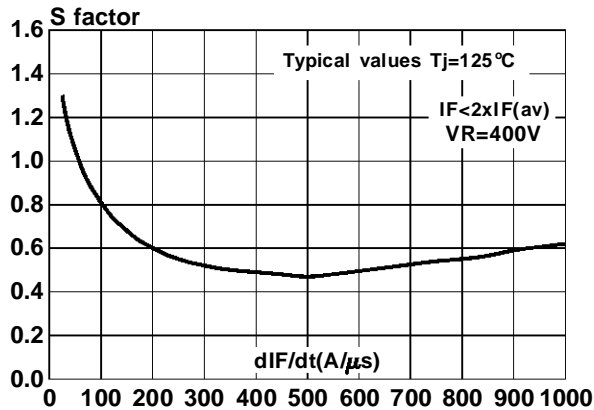

Fig 14 : Relative variation of dynamic parameters versus junction temperature (Reference  $T_j = 125^\circ C$ )

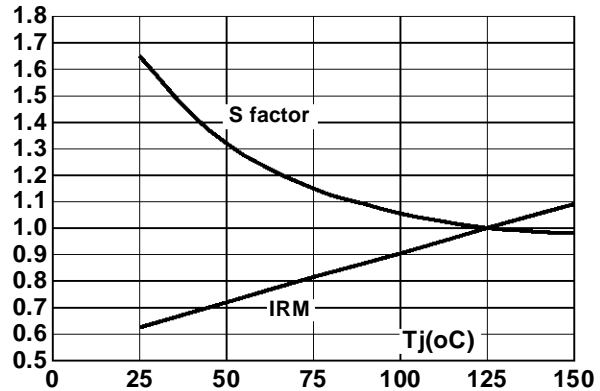

Fig 15 : Transient peak forward voltage versus  $dI_F/dt$

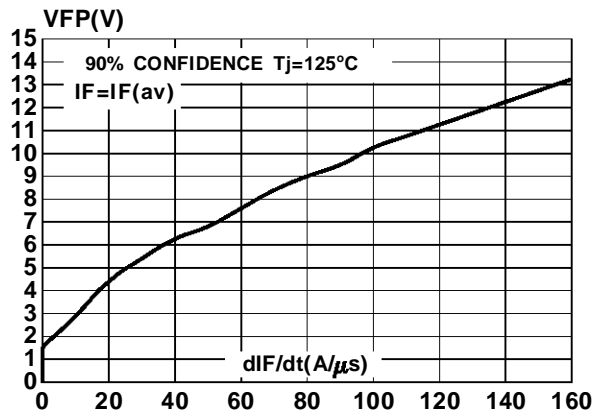
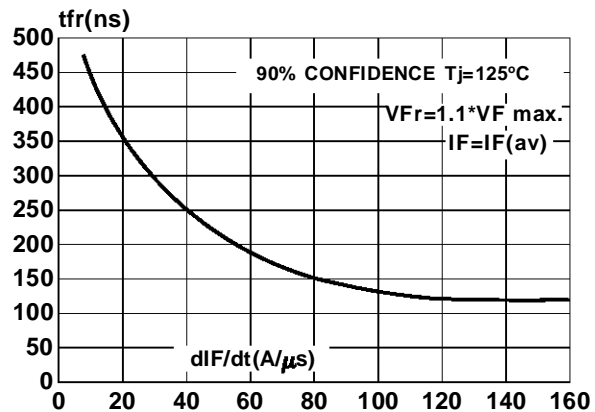
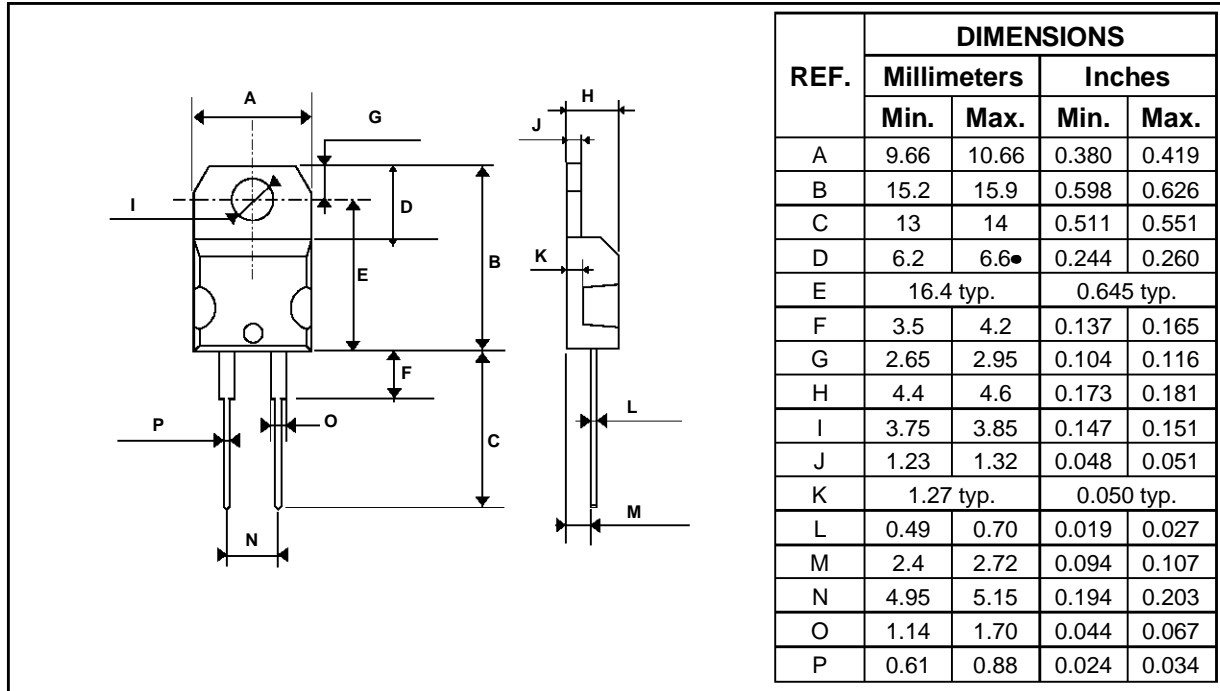

Fig 16 : Forward recovery time versus  $dI_F/dt$



**PACKAGE DATA**  
**TO220AC (JEDEC outline)**



Cooling method : C.  
 Marking : Type number.  
 Weight : 1.9 g.  
 Torque value : 0.55 m.N typ (0.70 m.N max).

**PACKAGE DATA**  
**ISOLATED TO220AC (JEDEC outline)**

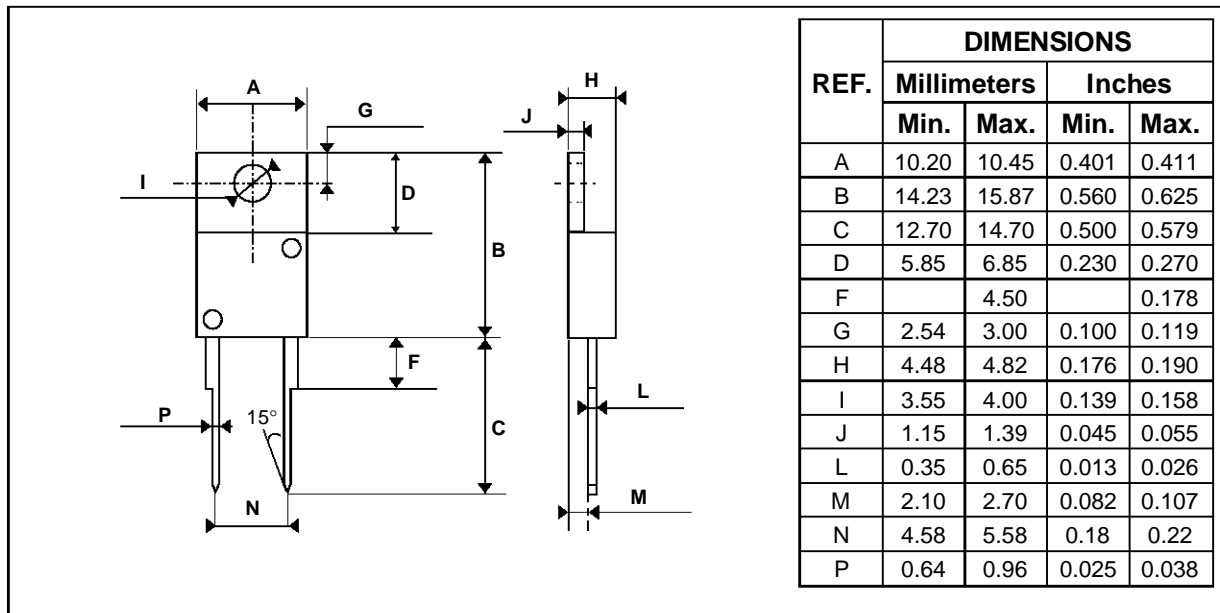

Cooling method : C.  
 Marking : Type number.  
 Weight : 2.2 g.  
 Torque value : 0.8 m.N typ (1.0 m.N max).

Electrical isolation : 2500V DC  
 Capacitance : 7 pF

Information furnished is believed to be accurate and reliable. However, SGS-THOMSON Microelectronics assumes no responsibility for the consequences of use of such information nor for any infringement of patents or other rights of third parties which may result from its use. No license is granted by implication or otherwise under any patent or patent rights of SGS-THOMSON Microelectronics. Specifications mentioned in this publication are subject to change without notice. This publication supersedes and replaces all information previously supplied. SGS-THOMSON Microelectronics products are not authorized for use as critical components in life support devices or systems without express written approval of SGS-THOMSON Microelectronics.

© 1995 SGS-THOMSON Microelectronics - Printed in Italy - All rights reserved.

SGS-THOMSON Microelectronics GROUP OF COMPANIES

Australia - Brazil - France - Germany - Hong Kong - Italy - Japan - Korea - Malaysia - Malta - Morocco - The Netherlands  
- Singapore - Spain - Sweden - Switzerland - Taiwan - Thailand - United Kingdom - U.S.A.